

SECTION B-B

SECTION TYPE 4

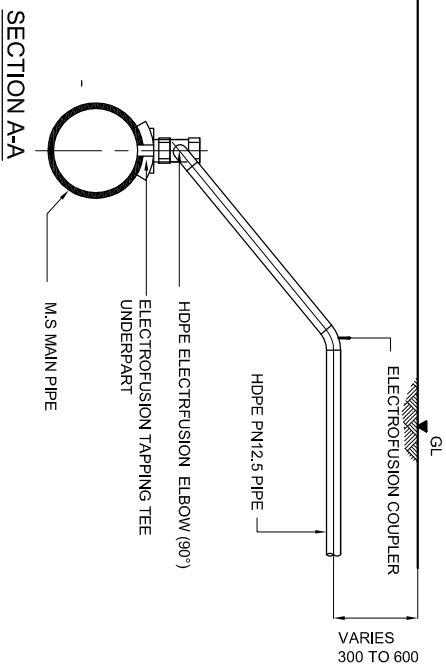

SECTION A-A

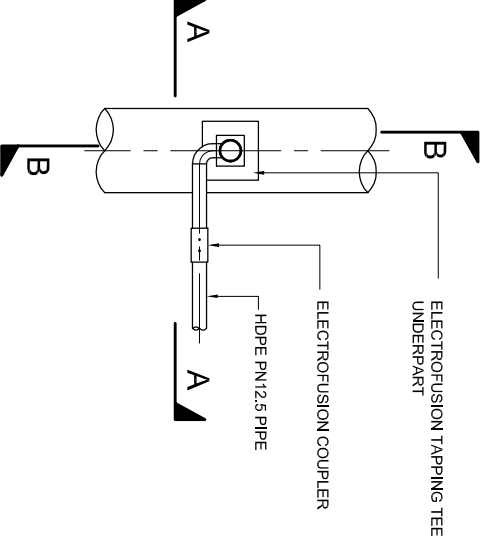

PLAN

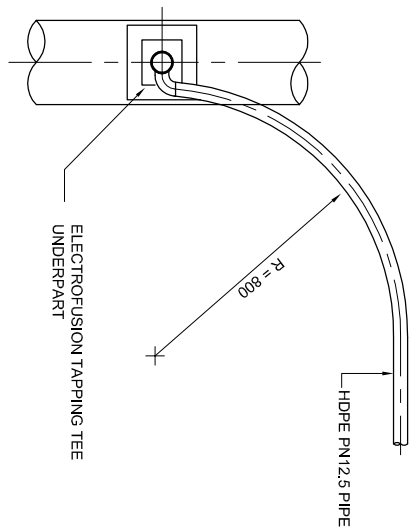

PLAN (TYPE '2')

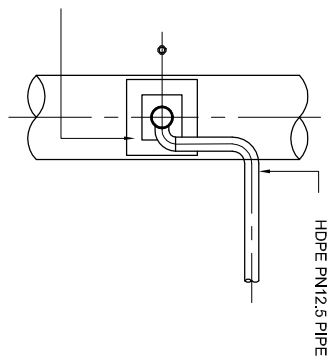

PLAN (TYPE '3')

- NOTES:-**
1. ALL DIMENSIONS ARE IN MILLIMETRE UNLESS OTHERWISE STATED.
  2. ACTUAL LENGTH OF COMMUNICATION PIPE SHALL BE DETERMINED ON SITE.
  3. ALL CONCRETE TO BE GRADE 25 UNLESS OTHERWISE STATED.



SURJUANALAYA PERKHIDMATAN AIR NEGARA  
 Ansa Bambi & Ansa Senu  
 Prima Avenue, Blok 3310  
 Jalan Tanjong 6,  
 Seksyen 13, Bandar  
 Salangor Damai, Enson, Malaysia

PREPARED BY :  
**MINCONSULT SDN. BHD.**  
 No. 6, JALAN 514/223,  
 48100 PERLIS JAYA,  
 SELANGOR DARUL EHSAN, MALAYSIA  
 m i n c o  
 TEL 03-79547272 / 79547273  
 FAX 03-79547275 / 79547273

DRAWING TITLE :  
**DETAILS OF HDPE COMMUNICATION  
 PIPE AND TAPPING FROM MILD STEEL  
 RETICULATION PIPE**

DRAWING NO :  
 SPAN/WSS/STD/F/026